

R66[®] *TURBINE*



ROBINSON HELICOPTER COMPANY

R66[®] *TURBINE*

The **R66 TURBINE** incorporates many of the design features of the R44 including a two bladed rotor system, T-bar cyclic and an open cabin configuration. Notable differences are the R66's increased reserve power, improved altitude performance, fifth seat and dedicated baggage compartment. Robinson's R66 delivers turbine power, performance and quiet comfort at a lower cost.

With continued focus on safety, the R66 meets the latest FAA crashworthiness regulations. After five years of research and development, the R66's design includes a well constructed cabin, energy absorbing seats and a new bladder fuel system. Its open cabin configuration comfortably seats five adults with passenger views that are not obstructed. Increased capacity, lower acquisition and operating costs, make the R66 the ideal helicopter for private, business and utility applications.



ROLLS ROYCE RR300 TURBOSHAFT ENGINE

is a derivative of the RR250 series specifically designed for the R66. The RR300 turbine engine operates on readily available jet A fuel delivering excellent power and responsiveness in a light-weight, compact installation.

SIMPLIFIED STARTING PROCEDURE

A latching starter and a fuel cutoff control which is separate from the collective twistgrip reduces the chance of over-tempering during start-up.

ENGINE MONITORING UNIT (EMU)

continuously records gas generator/ compressor rpm, turbine rpm, engine torque, and measured gas temperature (MGT). An engine anti-ice system is also standard.

OPTIONAL UPGRADES

AIR CONDITIONING

The air conditioning system features front and rear vents which circulate cool air throughout the cabin.

The air conditioning system weighs 42 pounds and has a 17,000 Btu/hr cooling capacity.

PILOT'S AVIONICS CONSOLE places a GPS unit in an easy-to-see and reach position, minimizing time spent looking down. The console can accommodate a GPS, GPS/COM, or GPS/NAV/COM.

BOSE A20 AVIATION HEADSETS with active noise reduction and Bluetooth communications interface.

AVIONICS

COM radio and transponder are standard. A variety of Bendix/King and Garmin avionics upgrades are available.

R66 COCKPIT

Shown with 7-hole instrument panel and optional Pilot's Avionics Console

Shaded area indicates silhouette of optional 9-hole instrument panel →



FEATURES



Open cabin design comfortably seats five adults.

TRI-HINGE ROTOR DESIGN eliminates lag hinges, dampers, and hydraulic struts. Blades resist corrosion and have thick leading edges to minimize erosion.

AIR VENTS in each door and in the nose provide fresh air for pilot and passengers.

GROUND HANDLING is made easy with ground handling wheels. A tow cart adaptor is included for use with Robinson's optional electric tow cart.

HYDRAULIC POWER CONTROLS eliminate stick shake and control forces enabling precise hovering and a smoother ride.

ROTOR BRAKE enables the pilot to stop the rotor blades more quickly reducing shutdown time and risk of injury to bystanders.

CENTER-POSITIONED CYCLIC Robinson's center-positioned teetering T-Bar cyclic makes it easy to enter and exit the cockpit. Left-seat flight controls are removable.

PISTOL-GRIP CYCLIC incorporates two-position trigger switches for intercom and transmit. Pilot-side grip has buttons for convenient switching of COM frequencies.

BAGGAGE COMPARTMENT The spacious 18 cubic-foot, 300 lb capacity compartment can accommodate three or four full-size suitcases. Additional storage space is provided under each seat for personal belongings.



SERVICE

No scheduled maintenance is required between 100 hour inspections. Main and tail rotor drive systems use maintenance-free flexible couplings in place of universal joints or gear couplings. Primary controls actuate by bell cranks and push-pull tubes eliminating cables and pulleys. Teflon lined bearings reduce periodic lubrication requirements.

TIME-BETWEEN-OVERHAUL (TBO) is 2000 hours or 12 years for the airframe and 2000 hours or 3000 start cycles for the engine, whichever occurs first. All life limited components have approved service lives of at least 2000 hours.

WORLDWIDE SERVICE is readily available with factory trained technicians at Robinson approved service centers throughout the world.

WARRANTY

The R66 comes with a two year or 1,000 hour limited aircraft warranty.

R66[®] TURBINE

SPECIFICATIONS

Engine Type	Rolls Royce RR300 300 shp turboshaft derated to 270 shp for takeoff and 224 shp continuous
Maximum Gross Weight	2700 lb (1225 kg)
Approximate Empty Weight (including oil & std avionics)	1280 lb (581 kg)
Fuel Capacity (73.6 gal)	493 lb (224 kg)
Passengers and Baggage with Maximum Fuel	927 lb (420 kg)
Cruise Speed	up to 125 kts (144 mph)
Maximum Range (no reserve)	approx 325 nm (375 sm)
Hover Ceiling IGE at Maximum Gross Weight	over 10,000 ft
Hover Ceiling OGE at Maximum Gross Weight	over 10,000 ft
Rate of Climb	over 1000 fpm
Maximum Operating Altitude	14,000 ft
7-Hole Instrument Panel	standard
Electrical System	28 volt

STANDARD INSTRUMENTS

- Airspeed indicator
- Altimeter
- Digital outside air temperature gage
- Hour meter
- Magnetic compass
- Oil temperature & pressure gages
- Quartz clock
- Rotor/engine dual tachometer
- Vertical speed indicator
- N1 Tachometer
- Torque Meter
- Turbine Gas Temperature Indicator

ANNUNCIATOR LIGHT PANEL

- Engine fire
- Low fuel
- Low oil pressure
- Low rotor RPM
- Main gearbox temperature
- Main gearbox chip
- Tail rotor gearbox chip
- Engine chip
- Anti ice
- Gen
- Fuel filter
- Cowl Door
- Air filter
- EMU

STANDARD EQUIPMENT

- Leather seats
- HID landing lights
- Anti-collision light
- Belly hard point
- Cabin heater and defogger
- Door locks
- Floor and hand intercom switches
- Navigation, panel and map lights
- Integrated oil filter w/bypass indicator
- Engine air filter w/bypass indicator
- 160 Amp starter generator
- Engine compressor rinse nozzle
- Pilot-side adjustable pedals
- Rotor blade tie downs
- Tinted windscreen and windows
- Tow cart adapter
- Windshield cover
- Robinson travel bag

DIMENSIONS

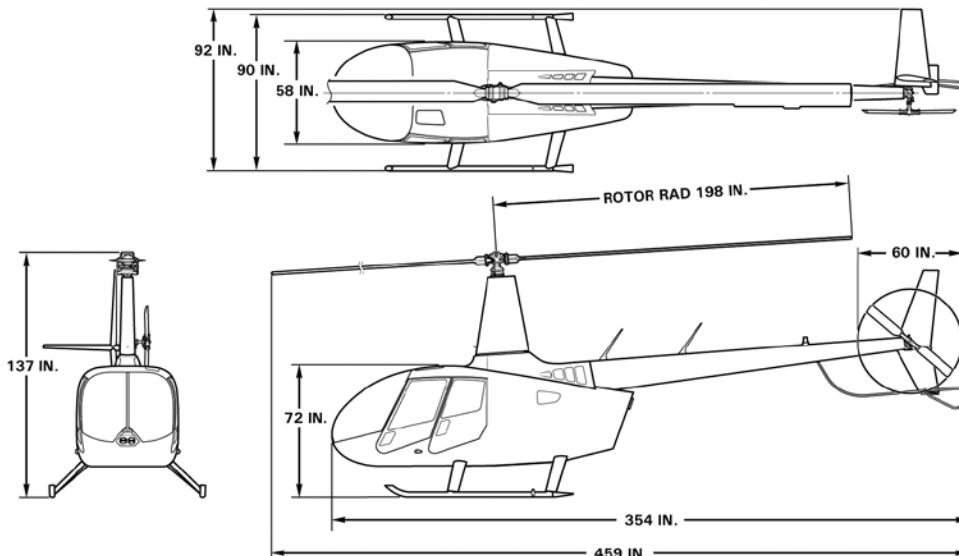

R66[®] TURBINE



QUALITY MANUFACTURING

To ensure the highest quality, Robinson manufactures, assembles, inspects and flight tests all of its helicopters at its Torrance, California factory. The facility features state of the art equipment including computer numerically controlled (CNC) machining centers, electrical discharge machines (EDM), and water jet and laser cutting machines. Coordinate measuring machines (CMM) capable of checking dimensional tolerances within 3 microns or 120 millionths of an inch are used to inspect precision machined parts. This level of accuracy is essential to the design and fabrication of interchangeable parts.

To maximize efficiency and productivity, a large percentage of parts are manufactured in-house allowing the company to better control costs, eliminate delays and ensure the best possible quality.



Robinson's 617,000 square foot facility.



Flight test



CNC machining centers

ROBINSON HELICOPTER COMPANY

2901 Airport Drive • Torrance, CA • 90505 • USA
Phone: 310-539-0508 • Fax: 310-539-5198
www.robinsonheli.com