

R44[®] RAVEN & CLIPPER HELICOPTERS



ROBINSON HELICOPTER COMPANY

R44[®] RAVEN HELICOPTERS

The **ROBINSON R44 RAVEN SERIES** provides excellent reliability, responsive handling, and altitude performance, making the R44 ideal for private, business, and utility applications.

A powder-coated steel-tube structure gives the R44 a rigid yet lightweight airframe, while the aerodynamic fuselage optimizes air speed and fuel economy. The R44 comfortably seats four adults, and passenger views are unobstructed due to the R44's open cabin design. A low tail-rotor tip speed, heavy-duty muffler, and large cambered tail decrease flyover noise, resulting in a community friendly helicopter.

RAVEN I

Equipped with a Lycoming O-540 carbureted engine, the R44 Raven I offers performance and affordability. The Raven I features carburetor heat assist that enhances safety and reduces pilot workload by automatically adjusting carburetor heat in response to power changes by the pilot.

RAVEN II

The high-performance R44 Raven II has a Lycoming IO-540 fuel injected, angle-valve, tuned-induction engine, which eliminates the need for carburetor heat. The standard 28-volt electrical system ensures good starting performance in hot or cold weather and provides additional electrical power for optional equipment.



R44 Raven II delivers increased altitude performance.



The low operating cost makes the R44 Raven I an excellent flight trainer.

CENTER-POSITIONED CYCLIC

Robinson's center-positioned, teetering T-bar cyclic makes it easy to enter and exit the cockpit. Left-seat flight controls are removable.

PISTOL-GRIP CYCLIC

Ergonomic grips incorporate two-position trigger switches for intercom and transmit. Pilot-side grip features buttons for convenient switching of COM frequencies.

OPTIONAL UPGRADES

AIR CONDITIONING

Available on the Raven II, the air conditioning system features front and rear vents which circulate cool air throughout the cabin.

To ensure maximum aircraft performance, the air conditioner compressor automatically disengages when the engine nears full throttle. The air conditioning system weighs 33 pounds and has a 12,000 Btu/hr cooling capacity.

PILOT'S AVIONICS CONSOLE places a GPS unit in an easy-to-see and reach position, minimizing time spent looking down. The console can accommodate a GPS, GPS/COM, or GPS/NAV/COM.

AVIONICS

COM radio and transponder are standard. A variety of Bendix/King and Garmin avionics upgrades are available.

IFR TRAINER

A specially designed instrument flight training package to prepare and qualify IFR pilots.

LEATHER SEATS available in tan, blue, and gray.

BOSE A20 AVIATION HEADSETS with active noise reduction and Bluetooth communications interface.

RAVEN II COCKPIT

Shown with 7-hole instrument panel and optional Pilot's Avionics Console



← Shaded area indicates silhouette of optional 9-hole instrument panel

FEATURES



R44 Raven II Interior shown with optional leather seats.

HYDRAULIC POWER CONTROLS eliminate stick shake and control forces, enabling precise hovering and a smoother ride.

AUTOMATIC CLUTCH ENGAGEMENT simplifies the starting procedure and reduces the possibility of an overspeed during startup.

RPM GOVERNOR monitors engine speed and adjusts the throttle automatically to maintain optimal RPM.

VOICE-ACTIVATED INTERCOM eliminates the need to use intercom switches during doors-on flights. Floor and hand intercom switches are included for doors-off operations.

XENON HID LANDING LIGHTS are standard on the Raven II and optional on the Raven I. Xenon High Intensity Discharge (HID) lights provide superior illumination. HID bulb life exceeds 2000 hours.

TRI-HINGE ROTOR HUB eliminates lag hinges, dampers, and hydraulic struts. Blades have a stainless steel spar at the leading edge which resists erosion. Droop stops prevent excessive main rotor teetering while stopping or starting under normal operating conditions.

ROTOR BRAKE allows the pilot to stop the rotor quickly, reducing shutdown time and risk of injury to ground personnel and passengers.

AIR VENTS in the cabin provide fresh air for pilot and passengers.

STORAGE under each seat allows for carry-on bags, briefcases, and personal belongings.



Under-seat storage compartment

MAINTENANCE is simplified, requiring only oil changes between 100 hour inspections. Main and tail rotor drive systems use maintenance-free flexible couplings in place of universal joints or gear couplings. Primary controls are actuated by push-pull tubes and bell cranks, eliminating cables and pulleys. Teflon-lined bearings eliminate periodic lubrication requirements.

TIME-BETWEEN-OVERHAUL (TBO) Properly maintained, the R44 has an approved engine and airframe TBO of 2200 hours or 12 years. All life-limited components have approved service lives of at least 2200 hours or 12 years.

WORLDWIDE SERVICE is readily available with factory-trained technicians at more than 400 Robinson-approved service centers throughout the world.

WARRANTY All R44s have a two-year or 1000-hour limited aircraft warranty.

R44[®] RAVEN HELICOPTERS

SPECIFICATIONS

SPECIFICATION	RAVEN I	RAVEN II
Engine Type	Lycoming O-540 carbureted	Lycoming IO-540 fuel injected
Cylinders	6	6
Max Gross Weight	2400 lb	2500 lb
Approximate Empty Weight (including oil & std avionics)	1450 lb	1510 lb
Standard Fuel (29.5 gal)	177 lb	177 lb
Auxiliary Fuel (17.0 gal)	102 lb	102 lb
Passengers and Baggage with Standard Fuel	773 lb	813 lb
Cruise Speed	up to 113 kts (130 mph)	up to 117 kts (135 mph)
Max Range (no reserve)	approx 300 nm (350 sm)	approx 300 nm (350 sm)
Hover Ceiling IGE @ Gross Weight	6400 ft	8950 ft
Hover Ceiling OGE @ 2300 lb	4000 ft	7500 ft
Rate of Climb	over 1000 fpm	over 1000 fpm
Max Operating Altitude	14,000 ft	14,000 ft
7-Hole Instrument Panel	standard	standard
Electrical System	14V	28V

STANDARD INSTRUMENTS

- Airspeed indicator
- Altimeter (in-Hg)
- Rotor/engine dual tachometer
- Manifold pressure gage
- Vertical speed indicator
- Magnetic compass
- Cylinder head temperature gage
- Oil temperature & pressure gages
- Fuel quantity gages
- Ammeter
- Carburetor temperature gage (Raven I)
- Quartz clock
- Digital OAT gage/voltmeter
- Hourmeter

WARNING LIGHTS

- Alt low voltage
- Low fuel
- Low oil pressure
- Low rotor RPM (light and horn)
- Main gearbox temperature
- Main gearbox chip
- Tail gearbox chip
- Engine fire
- Rotor brake engaged
- Starter engaged
- Clutch actuator
- Governor off

DIMENSIONS

Apply to both Raven I and Raven II

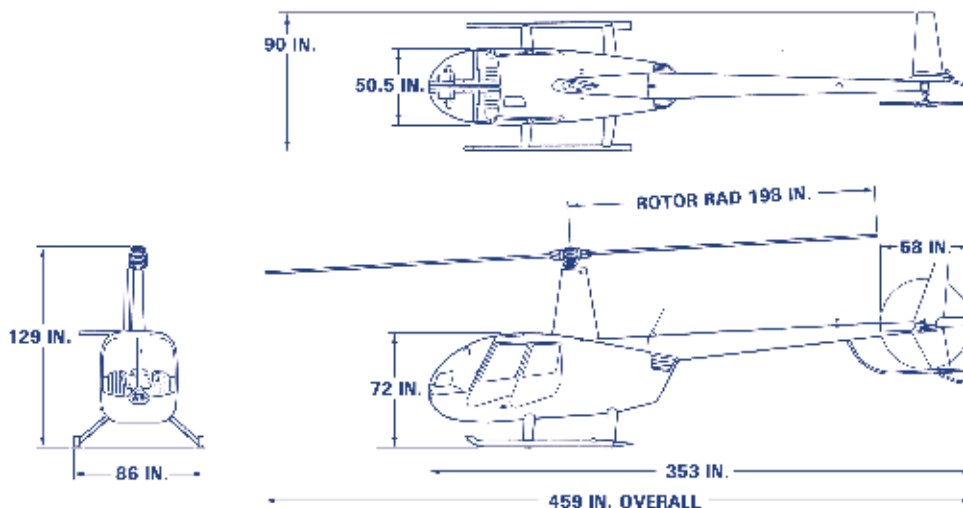

STANDARD EQUIPMENT

- Anti-collision light
- Dual landing lights
- Navigation, panel, and map lights
- Auxiliary fuel system
- Cabin heater and defogger
- Carbon monoxide detector
- Door locks
- Floor and hand intercom switches
- Pilot-side adjustable pedals
- Tinted windscreen and windows
- Belly hardpoint
- Tow cart adapter
- Oil filter and engine oil quick drain
- Ground handling wheels
- Rotor blade tie downs
- Windshield cover
- Robinson travel bag

R44[®] CLIPPER HELICOPTERS

The **ROBINSON R44 CLIPPER SERIES** are Ravens equipped with seaworthy floats and corrosion protection for over-water operations. The Clipper's low center-of-gravity provides excellent stability on water, and the float design enables safe emergency water landings and takeoffs. Special ground-handling wheels are included with each Clipper.

FIXED-UTILITY FLOATS

Available for both the Clipper I and Clipper II, fixed-utility floats add approximately 50 pounds to the aircraft's empty weight. Fixed-utility floats remain fully inflated and reduce cruise speed by approximately ten knots.

POP-OUT FLOATS

Available only on the Clipper II, pop-out floats have the same buoyancy as fixed-utility floats. The compact, low profile design minimizes the floats' impact on the helicopter's cruise speed and makes it easy to get in and out of the helicopter. Pop-out floats add 65 pounds to the helicopter's empty weight and, when not inflated, stow in snug sleeves along the skid tubes. A trigger on the collective deploys the floats, which inflate from a compressed helium-filled, carbon-fiber tank located under the left front seat.



R44 Clipper II, with pop-out floats stowed, on a residential rooftop helipad.



R44 Clipper I shown shipboard with optional rotor blade supports and frame tie-down lugs.

QUALITY MANUFACTURING

To ensure the highest quality, Robinson manufactures, assembles, inspects and flight tests all of its helicopters at its Torrance, California factory. The facility features state of the art equipment including computer numerically controlled (CNC) machining centers, electrical discharge machines (EDM), and water jet and laser cutting machines. Coordinate measuring machines (CMM) capable of checking dimensional tolerances within 3 microns or 120 millionths of an inch are used to inspect precision machined parts. This level of accuracy is essential to the design and fabrication of interchangeable parts.

To maximize efficiency and productivity, a large percentage of parts are manufactured in-house allowing the company to better control costs, eliminate delays and ensure the best possible quality.



Robinson's 617,000 square foot facility.



Flight test



CNC machining centers

ROBINSON HELICOPTER COMPANY

2901 Airport Drive • Torrance, CA • 90505 • USA
Phone: 310-539-0508 • Fax: 310-539-5198
www.robinsonheli.com